

## TETE-A-TETE COMPONENTS

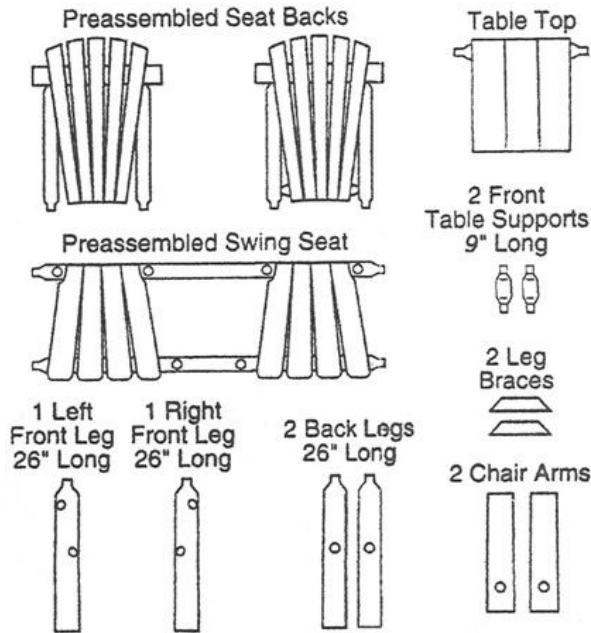

**NOTE: Cracks or Checks in logs are part of the natural beauty of cedar logs and should not be considered defects.**

### NOTE:

- **Read all instructions before starting.**
- To start hex washer head screws, hammer into wood about 1/2", then use wrench to tighten.
- Do not completely tighten any screws until the unit is fully assembled and setting on a level surface.
- Use a rubber mallet (or a block of wood between the hammer and the unit) to drive doweled ends into holes as far as possible.
- **If you have hardware left after assembly, it most likely has been assembled incorrectly and may not be safe to use.**

**STEP 1** Assemble front table supports into table top and back table support into seat backs as shown in figure 1. To make assembly easier, do not drive dowel completely into holes. Leaving them loose will allow for adjustments later in assembly.

## HARDWARE

(Not Shown Actual Size)

Twenty-Two 2-1/2" Screws



## TOOLS REQUIRED

Rubber Mallet or Block of Wood & Hammer      7/16" Wrench or Socket      #2 Phillips Screwdriver      Optional Battery or Power Drill

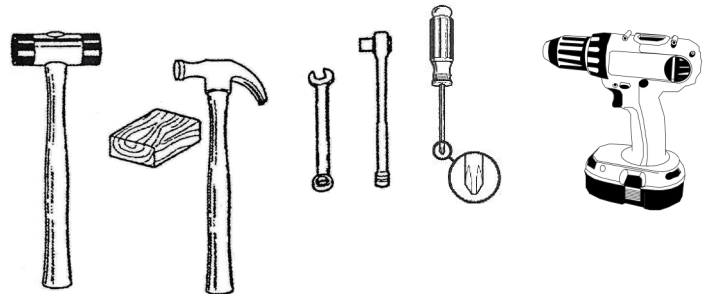

## TIPS

- A battery operated or electric drill will make assembly faster and easier.
- Use a good quality penetrating oil or wood deck sealer with a UV inhibitor. (Make sure product is intended for outdoor use.)
- If staining or finishing before assembling, tape off all dowel ends. (Finishes will cause the dowels to swell, making assembly difficult.)

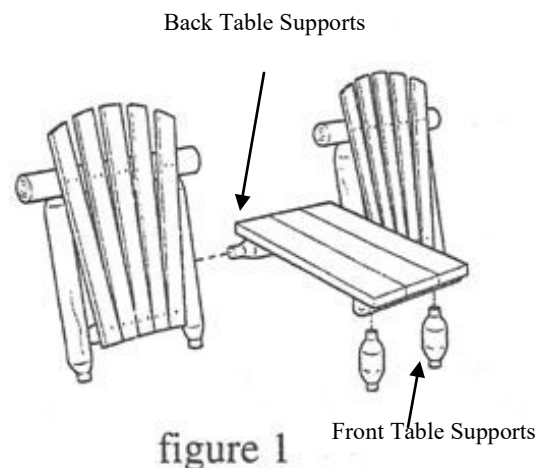

STEP 2 Lay assembled seat on ground. Insert dowel ends of assembled seat backs into the 1-1/4" holes on the back seat rail, adjusting uprights in or out as needed to align properly. Align front table supports into holes on front of seat rail (if table support dowels do not line up exactly to holes on front seat rail, turn supports until they line up and drop into holes). Do not tap on seat back with hammer. To keep the seat rail from splitting, lay the back on the ground and drive the seat on by hitting on the bottom of the seat assembly.

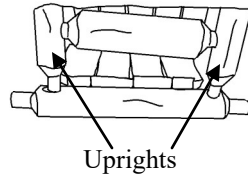

*Tapping Uprights—When the back, side uprights do not line up exactly with holes, gently tap the upright out, or in until they drop into holes.*

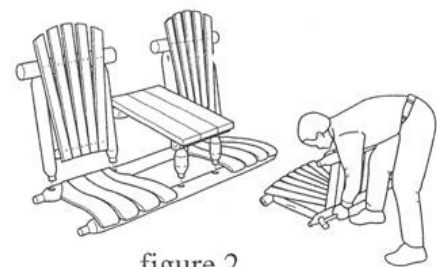

figure 2

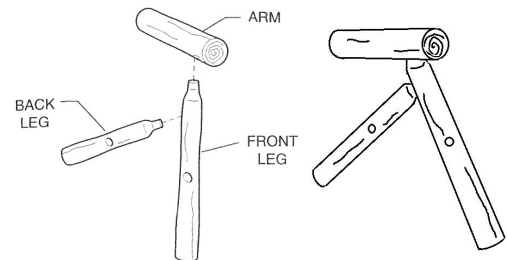

figure 3

STEP 3 Make a right leg assembly and a left leg assembly by inserting the dowel end of back leg into angled hole of front leg. The drilled holes on each leg should face the same direction as shown in figure 3. Put arms onto legs by inserting dowel end of front legs into the hole in the arms. Drive arm onto leg assembly as far as possible.

STEP 4 Set chair in upright position on a level surface and when legs are in proper position, bring ARM in against UPRIGHT. Tighten the preinstalled lag screws into the pilot hole in the arm with a wrench or socket. Secure doweled joints in place with screws perpendicular to the doweled ends as shown in figure 4 and figure 6. Repeat procedure for other side.



figure 4

STEP 5 With unit on a flat level surface, screw a brace onto each side; front leg to seat bottom as shown in figure 5. Secure all dowel joints with 2-1/2" screws. Insert screws perpendicular to the dowel as shown in the insert in figure 5.

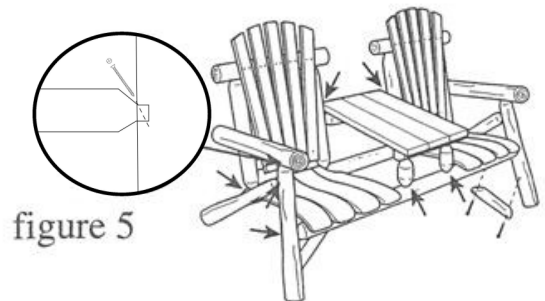

figure 5

Your Tete-a-Tete is now assembled and ready to finish or for immediate use.

**Lakeland Mills recommends:**

WeatherSeal Premium Oil-Based Exterior Wood Stain & Sealant  
www.ContinentalProd.com

Check all joints for tightness before and during each usage

*If you have hardware left over after completing your unit, it most likely has been assembled incorrectly, and may not be safe to use. Please call Customer Service at 800-427-5136 for assistance.*

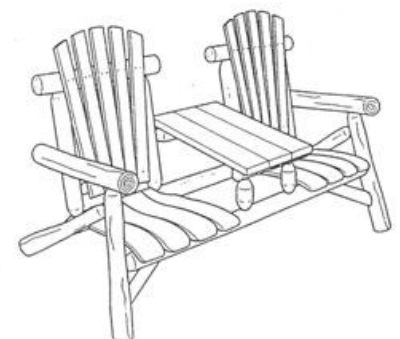

Like  
lakeland  
mills  
on



Look for assembly videos on:



<https://www.youtube.com/watch?v=aQhH4wr1DQw>